

o z o n e

PRODUCT SHEET: Brasilia S

Version: ENGLISH

Date: February 2024



o z o n e – Brasilia S

DESCRIPTION: Pendant light. White lacquered aluminum structure.
Mirror nickel aluminium stem. White paper diffusion material.
Warm white 2200K LED sources, 54W, 2400Lumens.
Converter 24V non-integrated, to be placed in a distant box.
Weight: 15kg - 31lbs
Size: 50x50x65cm - 19.7x19.7x25.6in + height of the hanging structure
Compliance: CE Class III
Origin: France

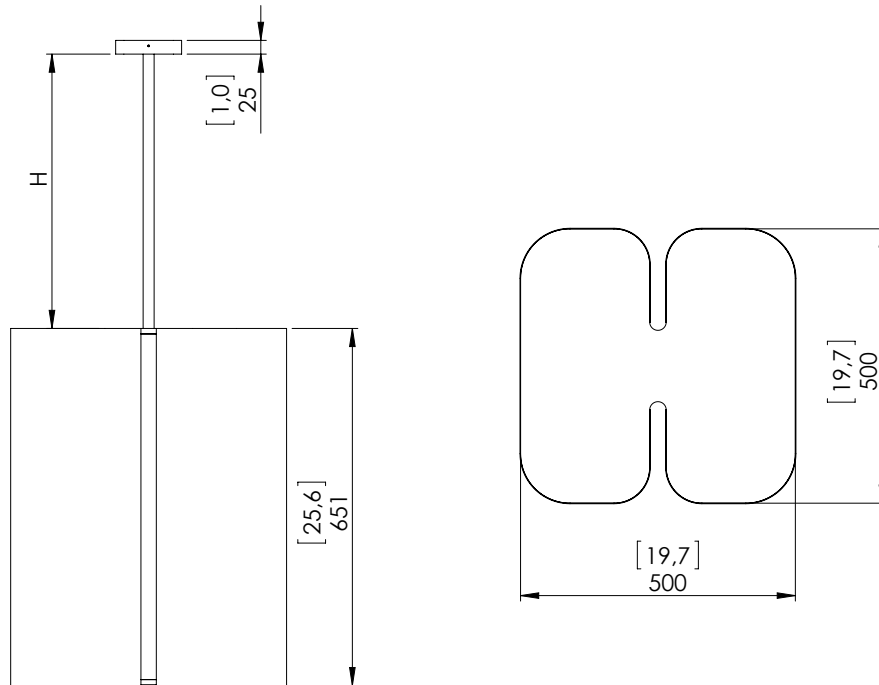

Dimensions in mm [inches]

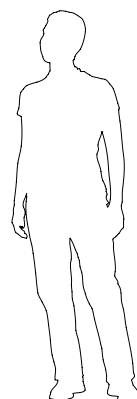
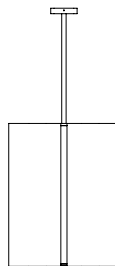

Silhouette :
175cm / 69in