

o z o n e

PRODUCT SHEET: Phénix

Version: ENGLISH

Date: February 2024



o z o n e - Phénix

DESCRIPTION: Wall lamp. Aluminum and brass structure, brushed gold finish.
Warm white 2700K LED sources, 23W, 1400Lumens (with a white wall).
Converter 500mA non-integrated, to be placed in a distant box.
Weight: 3kg - 5lbs
Size: 37x21x13cm - 14.6x8.3x4.9in
Compliance: CE Class III
Origin: Franc

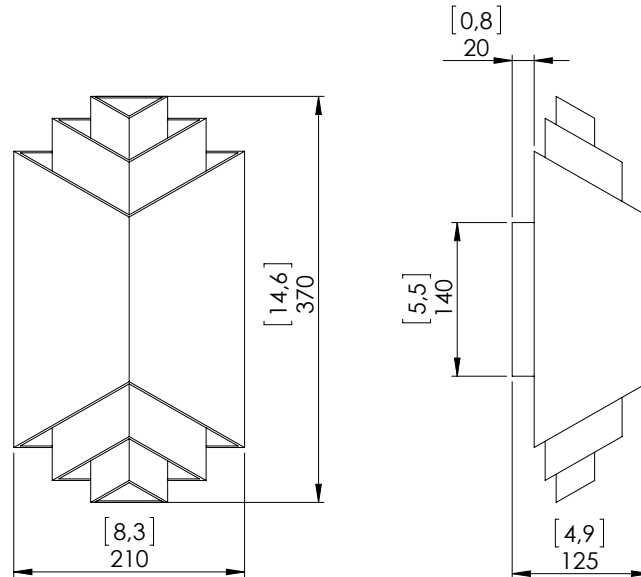

Dimensions in mm [inches]

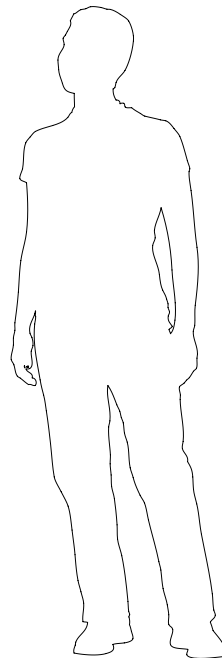
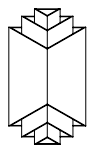

Silhouette :
175cm / 69in