

o z o n e

## PRODUCT SHEET: Tennessee S2 96

Version: ENGLISH

Date: April 2024



o z o n e – Tennessee S2 96

**DESCRIPTION:** Pendant light. Aluminium and brass structure.  
Finish in brushed bronze. White paper diffusing material.  
Warm white 2200K LED sources, 36W, 1600Lumens.  
Converter 24V non-integrated, to be placed in a distant box.  
Weight: 13kg – 28.7lbs  
Size: 96,2x34,4x7,2cm – 37.9x13.5x2.8in + Height of the hanging structure  
Compliance CE: Class III  
Origin : France

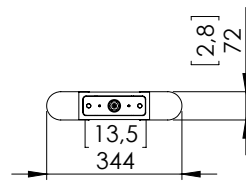
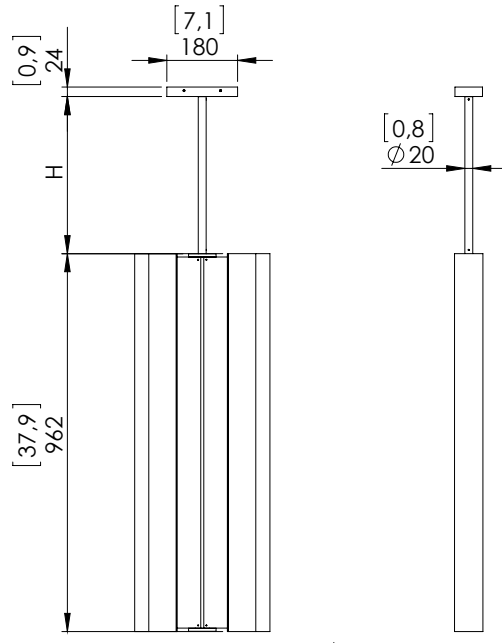

Dimensions in mm [inches]

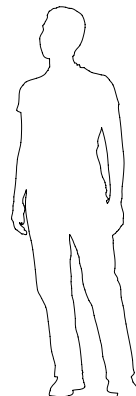
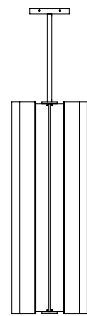

Silhouette: 175cm/69in