

o z o n e

PRODUCT SHEET: LINE C110

Version: ENGLISH

Date: June 2024



o z o n e – LINE C110

DESCRIPTION: Ceiling lamp.

White lacquered aluminum structure. White paper diffusing material.

Warm white 2200K LED sources, 76W, 3900Lumens.

Converter 24V non-integrated, to be placed in a distant box.

Weight: 26kg - 57lbs

Size: 110x110x16cm – 43.4x43.4x6.1in

Compliance: CE Class III

Origin: France

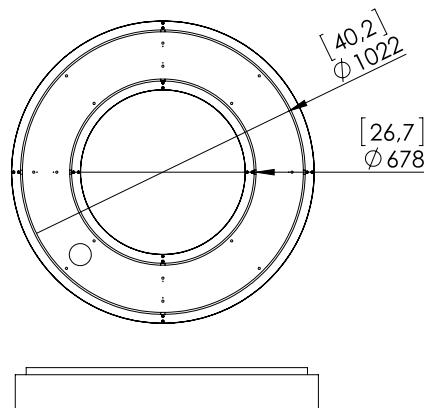
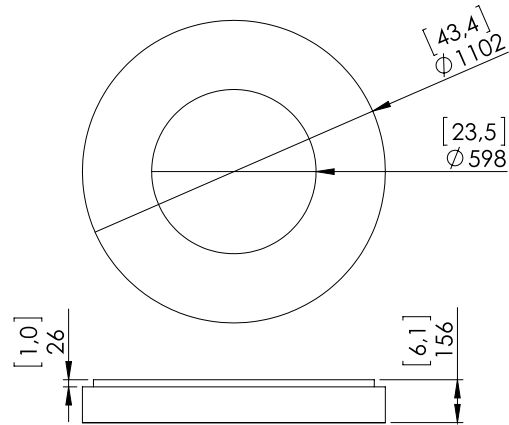

Dimensions in mm [inches]

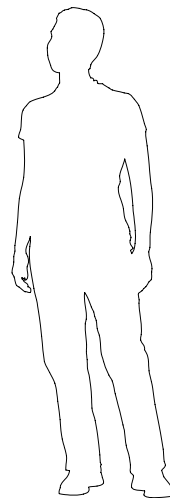

Silhouette : 175cm / 69in