

o z o n e

PRODUCT SHEET: Embrun LP

Version: ENGLISH

Date: April 2026



o z o n e – Embrun LP

DESCRIPTION: Table lamp. Aluminium, brass and steel structure.
Dark patinated brass finish. Honed white onyx shade.

Warm white LED lighting, Dim to Warm from 1900K (low intensity) to 2500K (high intensity),
33W, 1700Lumens.

Optional fixed light temperature, Warm white LED lighting 2200K, or alternatively 2700K, 28W,
1100Lumens.

Integrated 24V converters and driver.

Weight: 15kg – 33lbs

Size: 31x13x32cm – 12.2x5.1x12.5in

Compliance: CE Class I

Origin: France

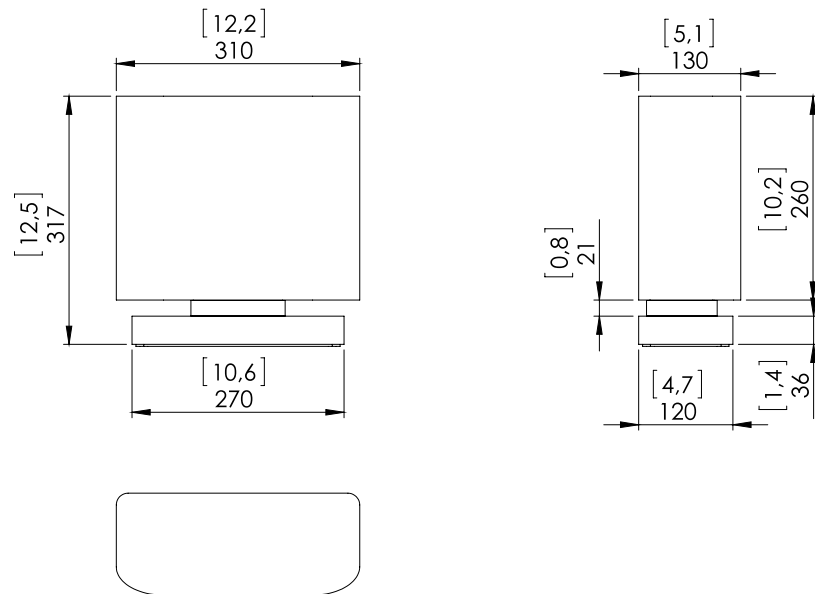

Dimensions in mm [inches]

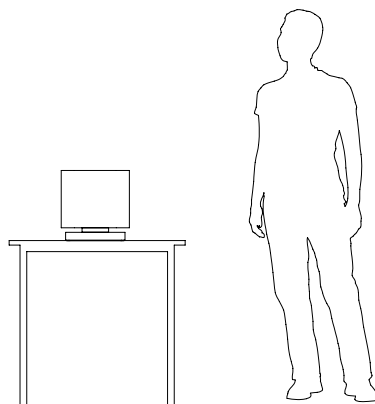

Silhouette : 175cm [69in]